

## 1268.4

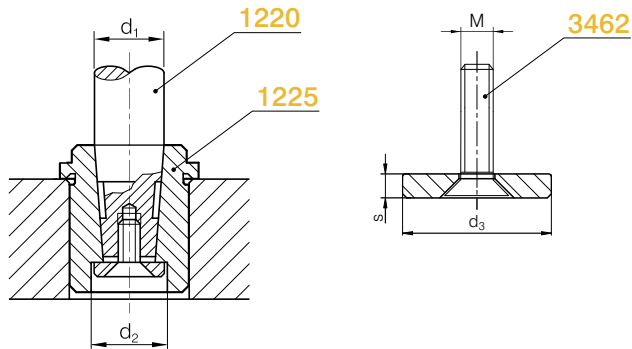

1268.4 - d<sub>1</sub>

s	M	d <sub>2</sub>	d <sub>3</sub>	d <sub>1</sub>
				1220
3	6	23	22	19 - 20
	8	26	25	24 - 25
5	10	33	32	30 - 32
	12	41	40	38 - 40
6	10	51	50	48 - 50
	12	64	63	60 - 63

## 1269 ISO

## DIN 9832

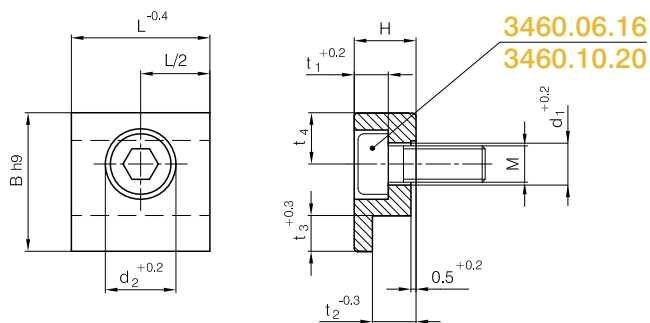

1269 ISO - t<sub>2</sub>

B	L	H	d <sub>1</sub>	d <sub>2</sub>	t <sub>1</sub>	t <sub>3</sub>	t <sub>4</sub>	M	t <sub>2</sub>
20	20	10	7	11	7	5	7,5	6x16	6,3
32	32	16	11,5	17,5	11,5	10	11	10x20	10
32	32	16	11,5	17,5	11,5	10	11	10x20	6