

M12 only by d₁ Ø80,100

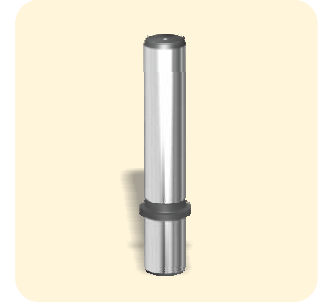

1211 - d₁ x L₁

L ₂	d ₄	d ₂	d ₁	L ₁	L ₂	d ₄	d ₂	d ₁	L ₁
40	68	32	25	125	70	93	60	50	250
				140					280
				160					315
				180					200
				200					224
42	75	40	32	140	80	106	80	63	200
				160					224
				180					250
				200					280
				224					315
56	83	50	40	160	100	123	90	80	224
				180					250
				200					280
				224					315
				250					355
70	93	60	50	160	125	143	110	100	200
				180					224
				200					280
				224					315
				224					355